



Barton® Model 200A/200AS Differential Pressure Indicator

User Manual

Manual No. 9A-10055, Rev. 01
January 2008

Table of Contents

SAFETY	2
SECTION 1 - INTRODUCTION	
1-1. General	3
1-2. Main Components	3
1-3. Indicator Specifications.....	3
SECTION 2 - INSTALLATION	
2-1. General	4
2-2. Mounting/Piping/DPU Installation	4
2-3. Startup.....	4
SECTION 3 - MAINTENANCE AND CALIBRATION	
3-1. Required Tools (Toolkit p/n 9A-0288-1032B)	5
3-2. DPU Installation/Test/Calibration/Maintenance	5
3-3. Bezel/Lens (or Cover) Installation and Removal	5
3-4. Calibration Check	5
3-5. Pointer Installation and Removal	6
3-6. Complete Calibration	6
3-7. Overrange Stop Adjustment	7
3-8. DPU Maintenance.....	8
3-9. Locking Drive Arm to Torque Tube.....	8
3-10. Troubleshooting	9
SECTION 4 - PARTS DRAWINGS/PARTS LISTS	
Table 4-1. 200A Parts List.....	11
Table 4-2. 200AS Parts List.....	13
SECTION 5 - INSTALL/DIMENSIONAL DRAWINGS	
Product Warranty	16

(This manual is for the Differential Pressure Indicator only. Before installing or operating this instrument, refer to Model 199 DPU manual, P/N 9A-10030.)



SAFETY

Before installing this instrument, become familiar with the installation instructions in Section 2 and in the Model 199 DPU manual.

DANGER notes indicate the presence of a hazard which will cause severe personal injury, death, or substantial property damage if warning is ignored.

WARNING notes indicate the presence of a hazard which can cause severe personal injury, death, or substantial property damage if warning is ignored.

CAUTION notes indicate the presence of a hazard which will or can cause moderate personal injury or property damage if warning is ignored.

DANGER, WARNING, and/or CAUTION notes that appear on the following pages of this manual should be reviewed before proceeding: None. (**Important! Before installing or operating this instrument, review all safety notices contained in the Model 199 DPU manual.**)

SECTION 1 - INTRODUCTION

1-1. General

The Barton Models 200A (standard case) and 200AS (optional 316 stainless steel case) indicators measure differential pressure, fluid flow rate, or liquid level. For fluid flow measurements, the indicator is connected by piping to the low- and high-pressure sides of a primary device (e.g., orifice plates, venturis, or flow tubes) located in the process run. For liquid level applications, variations in the level of the liquid within the process vessel produce changes in differential pressure used to indicate the liquid height.

The indicating pointer travels through a 270 degree arc over a six-inch diameter scale. The movement has a micrometer screw for range adjustment. Pointer hub adjustment can be made without removing the scale plate or pointer. Range and linearity adjustments are accessible after removal of the scale plate.

Model 200 AS is recommended for use in corrosive environments.

1-2. Main Components

The 200A consists of two major components: an actuating unit (differential pressure unit) and the case enclosed indicating instrument.

A. Actuating Unit (DPU) - Model 199 DPU. For detailed information on the actuating differential pressure unit, see the Model 199 DPU manual (P/N 9A-10030).

B. Case (Indicator)

1-3. Indicator Specifications

Accuracy:

0-10" w.c. to 0-349" w.c.

(255 mm to 890 m)..... $\pm 1/2\%$ of full-scale differential pressure

0-350" w.c. to 0-100 psi

(890 m to 6.7 bar)..... $\pm 3/4\%$ of full-scale differential pressure

Temperature Limits..... $-40^{\circ}\text{F}/^{\circ}\text{C}$ to $+180^{\circ}\text{F}$ ($+80^{\circ}\text{C}$);

$+35^{\circ}\text{F}$ to $+180^{\circ}\text{F}$ ($+1^{\circ}\text{C}$ to $+80^{\circ}\text{C}$) for water-filled units

Dimensionsper model number and housing rating. See outline dimensional drawings in section 5.

1-4. Theory of Operation

The bellows within the DPU moves in response to changes in the differential pressure monitored at the high and low pressure sides of the primary device installed in the process run. The DPU bellows movement is mechanically transferred to the indicator mechanism through a rotating torque tube shaft. As the torque tube rotates, the drive arm transmits the motion through the connecting link to the indicating pointer. The pointer travels through a 270 degree arc to indicate measurement on the 6-in. scale plate.

The 6-in. scale can be printed as required, in uniform increments for differential pressure, static pressure, or liquid height or in square-root increments for direct flow measurements. Special scales can be furnished to indicate the amount of liquid in a tank.

SECTION 2 - INSTALLATION

2-1. General

The instrument should be inspected at time of unpacking to detect any damage that may have occurred during shipment.

Note: The unit was checked for accuracy at the factory — do not change any of the settings during examination or accuracy will be affected.

For applications requiring special cleaning/precautions, a polyethylene bag is used to protect the instrument from contamination. This bag should be removed only under conditions of extreme cleanliness.

2-2. Mounting/Piping/DPU Installation

Refer to the Barton Model 199 DPU user manual (Part No. 9A-10030).

NOTICE: Do not turn instrument by grasping the instrument case - this can result in damage to the case. Always thread pipe into instrument.

2-3. Startup

For startup procedures, warning notices, and information, refer to the separate DPU Manual that is appropriate for the instrument model being installed.

SECTION 3 - MAINTENANCE AND CALIBRATION

3-1. Required Tools (Toolkit p/n 9A-0288-1032B)

Tool	Purpose
Pointer puller	Pointer removal
Small screwdriver	Calibration adjustments
Medium screwdriver	Bezel removal/DPU bracket screws
1/8" Open-end wrench	Calibration adjustments
1/8 Hex Allen wrench	Switch setpoint adjustment

3-2. DPU Installation/Test/Calibration/Maintenance

Refer to the Barton Model 199 DPU user manual (Part No. 9A-10030).

3-3. Bezel/Lens (or Cover) Installation and Removal

Whenever the bezel/lens is installed, the bezel gasket (p/n 9A-0277-0026C) must be installed as shown below:

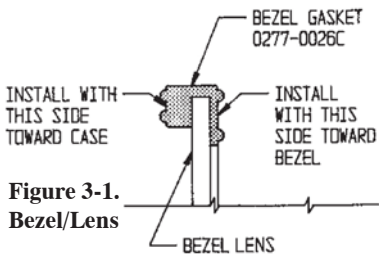

To remove the bezel and cover lens on non-explosionproof units:

1. Loosen three screws on the front of bezel.
2. Tilt out bottom of bezel and slide bezel upward.

The two snubbers (p/n 9A-0266-0028C) on the scaleplate should not be compressed against the lens cover and the pointer should not touch the lens.

Notice

Ensure correct bezel gasket orientation before placing instrument back in service. Incorrect bezel gasket orientation will cause the instrument indicator to jam, resulting in inaccurate readings.

3-4. Calibration Check

Normally all that is required to put switch into service is to verify that it remains at factory-set calibration, per the following:

1. Securely mount unit in an appropriately level position and connect DPU to a standard pressure source, per Model 199 DPU manual.
2. If zero indication is incorrect, remove bezel/lens (cover on explosionproof units) and reset pointer to zero. Note: For an exact zero setting, hold the hexagon hub with a wrench and carefully slip the pointer on its hub until it points to zero graduation. Replace bezel/lens (or cover).
3. To test for reverse travel, connect pressure source to LP housing and vent HP housing. Apply pressures approximately 150% of the differential pressure range. The pointer should move approximately 5% to 10% below zero.

4. To test for overtravel, connect pressure source to HP housing and vent LP housing. Apply pressures approximately 150% of the differential pressure range. Pointer should move approximately 5% to 10% above fullscale.
5. Apply 0%, 50% and 100% of full-scale pressure. If indication is within specified limits, instrument calibration is satisfactory and no adjustments are necessary. If indications are incorrect, perform calibration procedure (see section 3-6).
6. Make sure instrument zero indication is correct; otherwise, repeat Step 2.
7. Verify switch setpoints (see section 3-7, page 7).

3-5. Pointer Installation and Removal

A. Pointer Installation

1. Position pointer on movement shaft with pointer set at zero scale. If necessary, enlarge hub hole using a tapered broach (in toolkit) (p/n 9A-0288-1032B).
2. Lightly tap pointer hub with a hand-set or other flat-end tool. Use perpendicular blows to avoid bending shaft.
3. Check calibration over entire range (see section 3-8.). If unit is correctly calibrated, secure pointer to movement shaft by tapping hub with a hand-set or other flat-end tool.

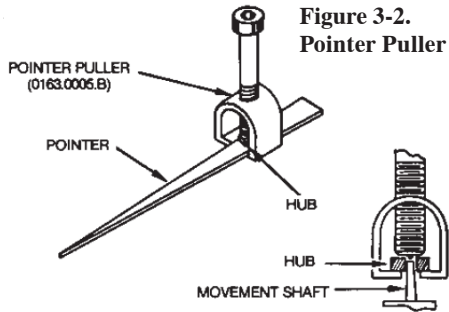

Figure 3-2.
Pointer Puller

B. Pointer Removal

Pointer is removed with Barton Pointer Puller (p/n 9A-0163-0005B), which is included in the toolkit (p/n 9A-0288-1032B).

1. Slide pointer puller along pointer until pin protruding from tip of screw in pointer puller is directly over movement shaft and arms of pointer puller are directly under pointer.
2. Gently turn knurled head of screw clockwise, pushing pin against movement shaft and lifting pointer with arms. Finger pressure should be sufficient to pull the pointer free. If more pressure is required, insert an Allen wrench into head of the screw for leverage. Avoid applying excessive pressure, which can cause the pin to break.

3-6. Complete Calibration

A complete calibration of the instrument is required whenever the DPU assembly is replaced. Refer to the Model 199 DPU manual before performing this calibration procedure.

1. Securely mount instrument in an approximately level position and connect DPU into the test setup, as described in the Model 199 DPU manual.
2. Align linkage between drive arm and movement. (Figure 3-3 shows proper alignment at 50% differential pressure.) Inspect parts for straightness and pivot-fit without binding.

3. Set pointer at zero on scale by slipping pointer on hub. Hold tip of pointer and turn hub with wrench.
4. Apply 100% differential pressure. If pointer exceeds 100% on scale, lengthen range arm. Remove pressure.
5. Set zero and span, using hub for zero adjustment and range adjust screw on the movement for span adjustments.
6. Apply 50% differential pressure. If pointer does not indicate 50% scale, a linearity adjustment is necessary. Loosen drive arm screw and move arm to shift pointer in direction of error (approx. 10:1). Tighten drive arm screw.
7. Release pressure and reset pointer at zero. Check the span. If gear in movement reaches limit of travel as a result of linearity adjustment (step 6), slip range arm along gear approximately 5 degrees from normal 37.5 degree angle to approximately 43 degrees. Range arm is slipped by applying pressure to range arm with thumb, while holding gear firmly in place. Retest pointer response at 50% and 100% differential pressure, and adjust linkage until readings are acceptable.

8. Apply 0%, 25%, 50%, 75%, 100%, 75%, 50%, 25%, and 0% of differential pressure consecutively to instrument without overshoot. Lightly tap indicator to overcome friction. Pointer should accurately indicate each applied pressure.

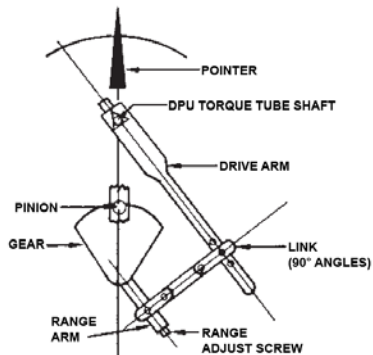
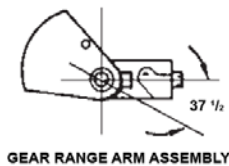

Figure 3-3.
Linkage Alignment
(50% DP)

9. Test instrument repeatability by applying 0%, 50%, 0%, 50% differential pressure. Indicator should accurately indicate each applied pressure.
10. Set overrange stops to prevent pointer from striking snubbers on scale. See section 3-7 (Overrange Stop Adjustment). Tighten all screws. Test setting by manually moving pointer from zero position to 50%, then let the pointer return freely. An off-set in zero reading indicates pointer slippage. If necessary, tap pointer hub to tighten it to shaft.

3-7. Overrange Stop Adjustment

1. Apply sufficient pressure to the high pressure housing to deflect the pointer against the snubber on the scale plate. Slide the upper overrange stop against the drive arm and tighten the overrange stop screw.
2. Apply sufficient pressure to the low pressure housing to deflect the pointer against the zero stop snubber on the scale plate. Slide the zero-stop against the drive arm and tighten the zero-stop screw.
3. Remove the pointer and calibration scale. Replace the pointer at zero (adjust zero as necessary). Replace the lens and bezel assembly.

3-8. DPU Maintenance

A. DPU inspection/cleaning/repair/service procedures, along with applicable WARNING notices, are presented in the Model 199 DPU manual.

3-9. Locking Drive Arm to Torque Tube

Refer to Model 199 DPU manual.

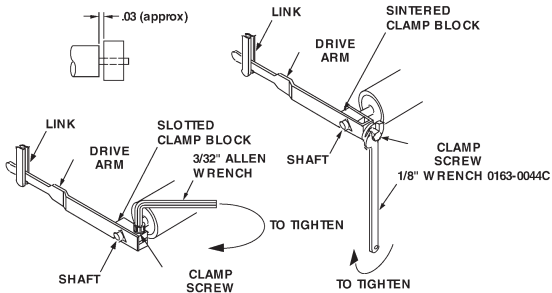

Figure 3-4. Locking Drive Arm to Torque Tube

1. Slip drive arm over torque tube shaft; clear end of torque-tube housing by approximately 0.030-inches before securing to prevent interference.
2. To tighten drive arm assembly onto torque-tube shaft:
 - a. While supporting block/shaft, tighten clamp screw until snug to shaf.
 - b. Still supporting block/shaft, tighten clamp screw an additional:
 - Sintered: 1/3 to 1/2 turn (This screw can normally turn one full revolution before breaking.)
 - Slotted: 1/4 to 1/3 turn (The slot in the slotted clamp block should still be open.)

3-10. Troubleshooting

Refer to Table 3-1 for troubleshooting information. Also, see the Model 199 DPU manual.

Table 3-1. Troubleshooting

Problem	Possible Source	Probable Cause	Corrective Action
Low or No Indication	DPU	—	See Model 199 DPU manual.
	Indicator	Loose movement	Tighten/replace movement.
		Out of calibration	Calibrate unit.
		Dirty or corroded mechanism	Clean/replace mechanism.
		Pointer loose	Tighten pointer.
High Indication	Piping or primary source	—	See Model 199 DPU manual.
	DPU	—	See Model 199 DPU manual.
	Indicator	Loose arms Out of Calibration	Tighten mechanism. Calibrate unit.
Erratic Indication	Primary Element	—	See Model 199 DPU manual.
	Piping	—	See Model 199 DPU manual.
	DPU	—	See Model 199 DPU manual.
	Indicator	Movement dragging or dirty	Adjust/clean movement.
		Pointer dragging on scale plate	Adjust pointer position.

SECTION 4 - PARTS DRAWINGS/PARTS LISTS

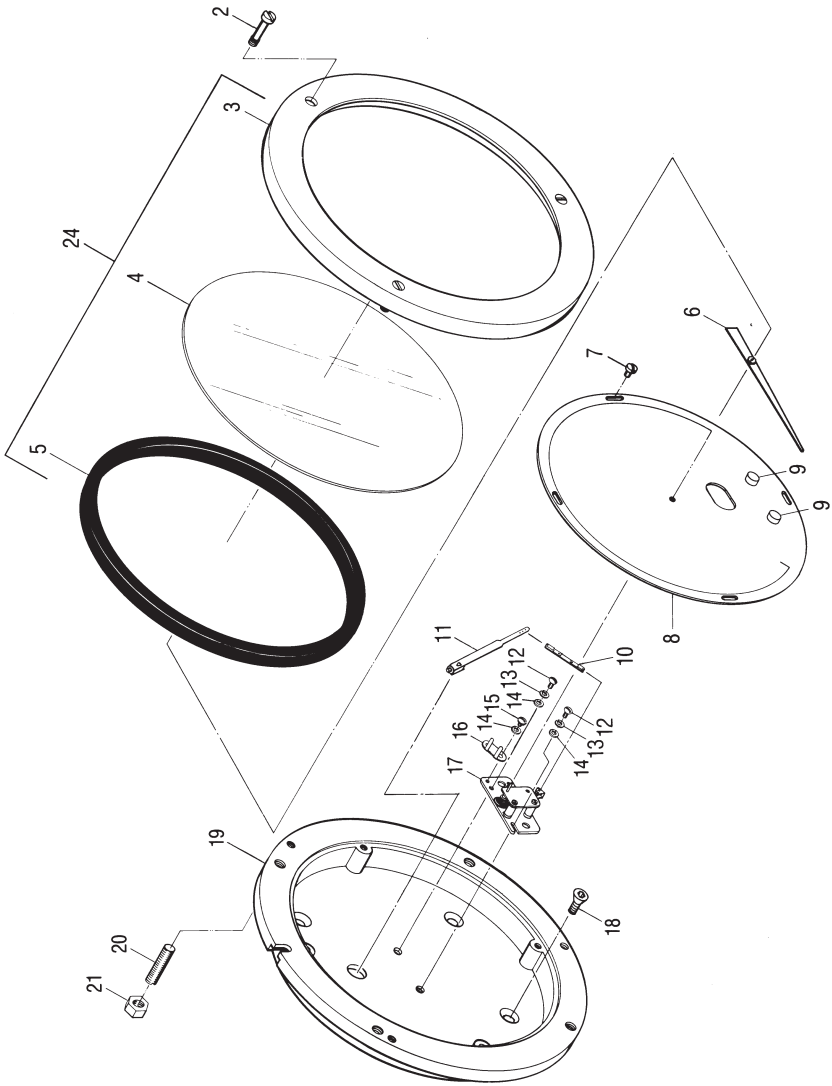

Figure 4-1. 200A Parts Drawing

Table 4-1. 200A Parts List

Item	Description	Part No.	Per Unit
1	DIFFERENTIAL PRESSURE UNIT, MODEL 199	SEE DPU MANUAL	1
2*	SCREW, BEZEL, SLOTTED	9A-0181-0007C	3
3	BEZEL (PART OF ITEM #24)	9A-0277-0029C	1
4*	LENS, COVER (PART OF ITEM #24)	9A-0181-0038C	1
5*	GASKET, BEZEL (PART OF ITEM #24)	9A-0277-0026C	1
6*	POINTER ASSEMBLY:		1
	WHITE	9A-0288-0030B	
	BLACK	9A-0288-0031B	
7*	SCREW, SCALE PLATE, 4-40 x 3/16, SST	9A-0114-0023J	4
8**	SCALE PLATE		1
	WHITE ON BLACK BACKGROUND	9A-0200-0051C	
	BLACK ON WHITE BACKGROUND	9A-0200-1014C	
9	STOP, SNUBBER	9A-0226-0028C	2
10*	LINK ASSEMBLY	9A-0288-0036B	1
11	DRIVE ARM ASSEMBLY	9A-0200-0015B	1
12	SCREW, 4-40 x 1/4, SST	9A-0111-0034J	2
13	WASHER, SPLIT LOCK, #4, SST	9A-0003-0062K	2
14	WASHER, FLAT, #4, SST	9A-0003-0096K	3
15	SCREW, 4-40 X 3/16, SST, SLOTTED	9A-0117-0012J	1
16	BAR, STOP, OVERRANGE	9A-0288-0028C	1
17	MOVEMENT ASSEMBLY	9A-0288-0035B	1
18*	SCREW, 1/4-20 X 1/2, STL. CD. PL., SOCKET	9A-0240-0009J	4
19	CASE	9A-0200-0052C	1
20	SCREW, 1/4-20 X 1, STL. CD. PL., SLOTTED	9A-0340-0003J	4
21	NUT, 1/4-20, HEX, STL. CD. PL.	9A-0500-0010J	4
22	PLATE, FLUSH MOUNTING ADAPTER (ITEMS 20 AND 21 USED WITH ITEM 22)(NOT SHOWN)	9A-0200-0014C	1
23	STUD, BEZEL, RETAINING, DRIV-LOK	9A-0004-0005K	1
24	BEZEL ASSEMBLY	9A-0277-0018B	1
25	CALIBRATION KIT (NOT SHOWN)	9A-0288-1032B	1
<p>* Recommended spare part ** Scale plate identification: If the scale plate shows an SCR number, this will identify it. Otherwise, provide the following information: 1. Square Root or Linear Graduations 2. Scale (e.g., 0-100, 25-0-100, etc.) 3. Number of Graduations (linear scales only) 4. Data (e.g., PSI (bar), inches of water column (meter), etc.) 5. Standard plates have white background. When ordering parts, specify serial number of instrument.</p>			



Use only spare parts identified in this manual. Cameron bears no legal responsibility for the performance of a product that has been serviced or repaired with parts that are not authorized by Cameron.

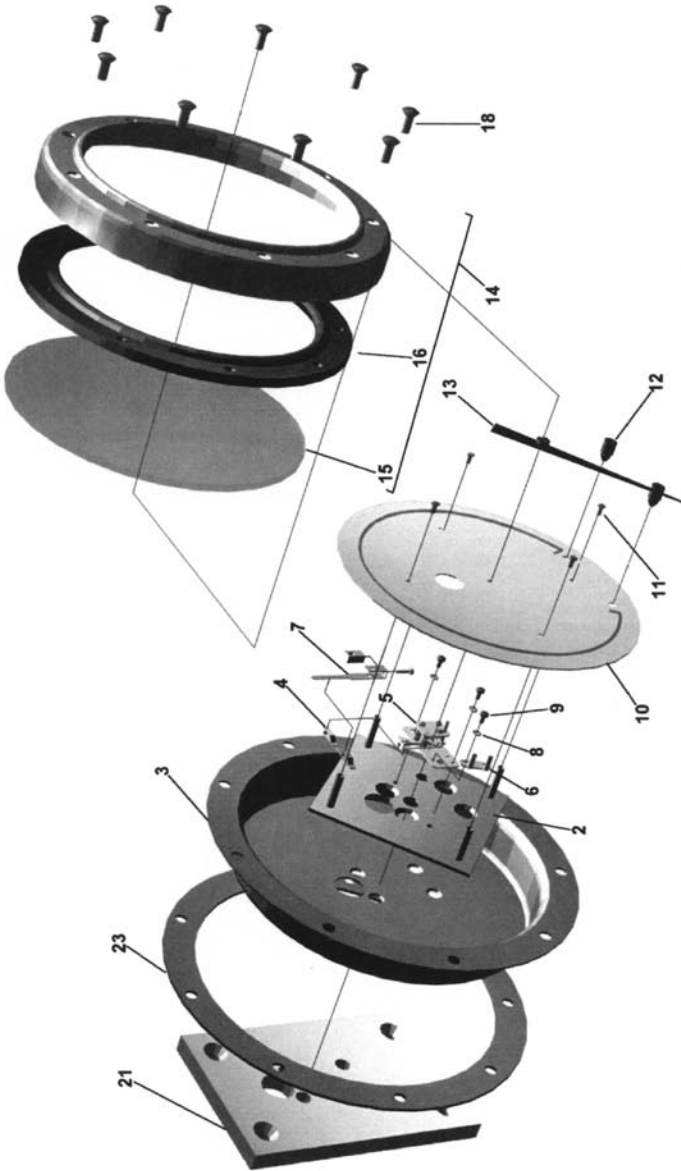

Figure 4-2. 200AS Parts Drawing
(with optional 316 stainless steel case)

Table 4-2. 200AS Parts List

Item	Description	Part No.	Per Unit
1	DIFFERENTIAL PRESSURE UNIT (NOT SHOWN)	SEE DPU MANUAL	1
2	MOUNTING PLATE, STAINLESS STEEL	9A-S961-0042C	1
3	CASE, INDICATOR, STAINLESS STEEL	9A-S961-0036C	1
4	LINK ASSY.	9A-0226-0020B	1
5	MOVEMENT ASSY.	9A-0129-1012T	1
6	BRACKET, STOP	9A-0288-0028C	1
7	DRIVE ARM ASSY.	9A-0226-0023B	1
8*	WASHER, SPLIT LOCK, #4, STAINLESS STEEL	9A-0003-0062K	2
9*	SCREW, BIN. HD., 4-40 x 3/16", SST	9A-0117-0012J	3
10	SCALE PLATE, ALUMINUM (DIV./UNITS SPECIFIED)	9A-S961-0051C-1	1
11	SCREW, SCALE PLATE, FIL HD. 4-40 X 3/16"	9A-0114-0023J	4
12	SNUBBER, POINTER, RUBBER	9A-0226-0028C	2
13*	POINTER ASSY., ALUMINUM:		1
	BLACK	9A-0288-0031B	
	WHITE	9A-0288-0030B	
14	BEZEL	9A-S961-0037C	1
15	LENS	9A-S961-0038C	1
16	GASKET, LENS, RUBBER	9A-S961-0039C	1
17	NOT USED		
18	SCREW, BEZEL, ISO M5 C/SUNK DOMED HD., STAINLESS STEEL	9A-S961-0041C	9
19*	CALIBRATION KIT (NOT SHOWN)	9A-0288-1032B	1
20	SCREWS, CASE MOUNTING, 10-32 UNC, STEEL (NOT SHOWN)	9A-0240-0019J	4
21	BRACKET, SPACER PLATE, STAINLESS STEEL	9A-S961-0044C	1
22	SCREW, CAP. BRACKET, SPACER PLATE, 1/4 UNC, STEEL (NOT SHOWN)	9A-0240-0009J	4
23	RING, FLANGE, THREADED, STAINLESS STEEL	9A-S961-0040C	1

* Recommended spare parts.



Use only spare parts identified in this manual. Cameron bears no legal responsibility for the performance of a product that has been serviced or repaired with parts that are not authorized by Cameron.

SECTION 5 - INSTALL/DIMENSIONAL DRAWINGS

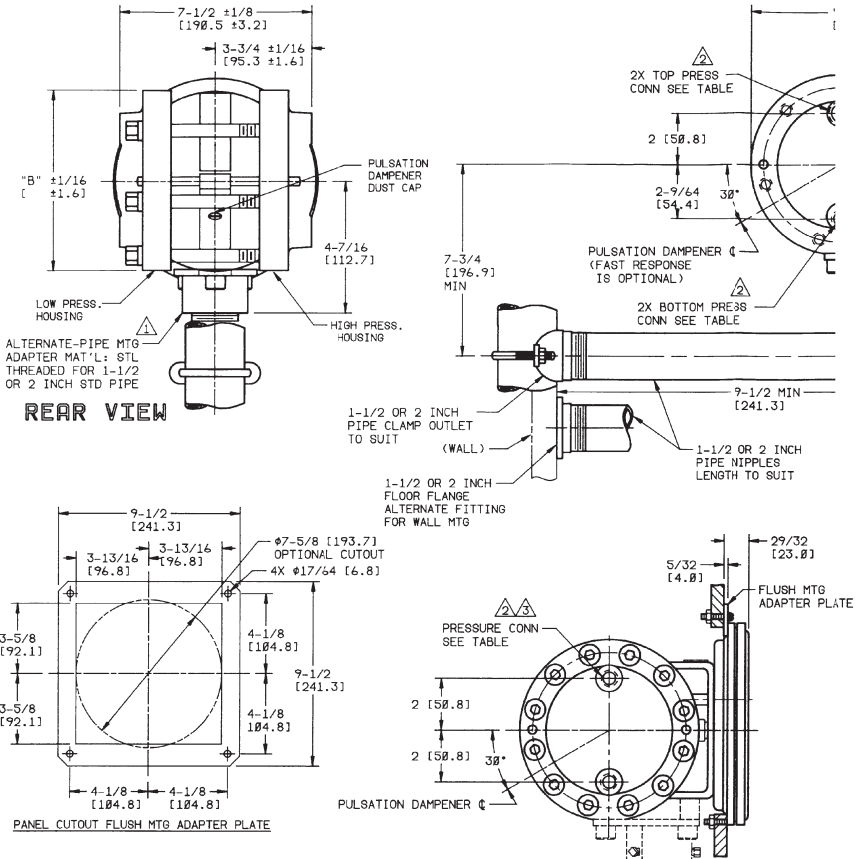

1000 PSI	8-29/32 [226.2]	Ø6-5/8 [168.3]	1/2 NPT	1/4 NPT	12	FGD SST, 316
					6	FGD STL, C1018
						CAST ALUM
2500 PSI			1/2 NPT	1/4 NPT	6	FGD STL, C1018
3000 PSI					12	FGD SST, 316
4500 PSI	9-5/32 [232.6]	Ø7-1/8 [181.0]	9/16-18	9/16-18	12	FGD STL, 4142
6000 PSI						FGD SST, 329
6000 PSI			1/2 NPT	1/4 NPT	12	FGD STL, 4142
						FGD SST, 329
PRESSURE RATING	DIM "A"	DIM "B"	TOP PRESSURE CONN	BOTTOM PRESSURE CONN	NO. OF BOLTS	HSG MATERIAL

SIDE VIEW

PANEL MOUNTING
6000 PSI UNIT

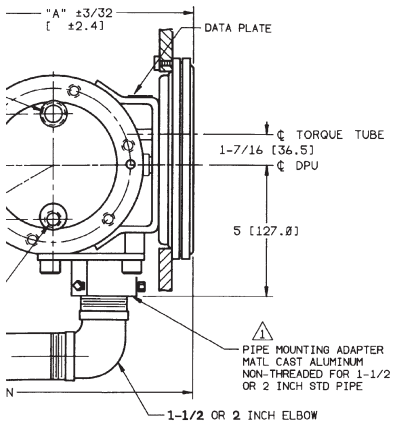

SIDE VIEW

PIPE MOUNTING

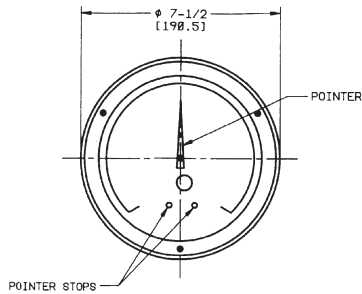

FRONT VIEW

(MOUNTING NOT SHOWN)

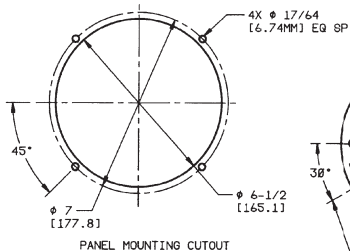

PANEL MOUNTING CUTOUT

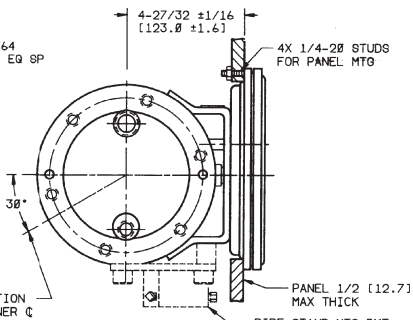

SIDE VIEW

PANEL MOUNTING

- 6. DIMENSIONS IN [] ARE IN MILLIMETERS.
- 5. FOR PANEL MOUNT REMOVE HEADS & PIPE MOUNTING BRACKET.
- 4. ALL STANDARD PIPE FITTINGS FURNISHED BY CUSTOMER.
- ③ SUITABLE FOR USE WITH AMINCO FITTINGS: AMERICAN INSTR. CO., SILVER SPRING, MD, OR EQUIV.
- ② CAN BE REVERSED WHEN ORDERED OR ROTATED 180° IN THE FIELD.
- ① PIPE MTO ADAPTER OF CAST ALUMINUM WILL BE FURNISHED UNLESS OTHERWISE SPECIFIED. SPECIFY PIPE SIZE WHEN ORDERING THREADED STEEL ADAPTER.

NOTES: UNLESS OTHERWISE SPECIFIED

Product Warranty

A. Warranty

Cameron International Corporation ("Cameron") warrants that at the time of shipment, the products manufactured by Cameron and sold hereunder will be free from defects in material and workmanship, and will conform to the specifications furnished by or approved by Cameron.

B. Warranty Adjustment

- (1) If any defect within this warranty appears, Buyer shall notify Cameron immediately.
- (2) Cameron agrees to repair or furnish a replacement for, but not install, any product which within one (1) year from the date of shipment by Cameron shall, upon test and examination by Cameron, prove defective within the above warranty.
- (3) No product will be accepted for return or replacement without the written authorization of Cameron. Upon such authorization, and in accordance with instructions by Cameron, the product will be returned shipping charges prepaid by Buyer. Replacements made under this warranty will be shipped prepaid.

C. Exclusions from Warranty

- (1) THE FOREGOING WARRANTY IS IN LIEU OF AND EXCLUDES ALL OTHER EXPRESSED OR IMPLIED WARRANTIES OF MERCHANTABILITY, OR FITNESS FOR A PARTICULAR PURPOSE, OR OTHERWISE.
- (2) Components manufactured by any supplier other than Cameron shall bear only the warranty made by the manufacturer of that product, and Cameron assumes no responsibility for the performance or reliability of the unit as a whole.
- (3) "In no event shall Cameron be liable for indirect, incidental, or consequential damages nor shall the liability of Cameron arising in connection with any products sold hereunder (whether such liability arises from a claim based on contract, warranty, tort, or otherwise) exceed the actual amount paid by Buyer to Cameron for the products delivered hereunder."
- (4) The warranty does not extend to any product manufactured by Cameron which has been subjected to misuse, neglect, accident, improper installation or to use in violation of instructions furnished by Cameron.
- (5) The warranty does not extend to or apply to any unit which has been repaired or altered at any place other than at Cameron's factory or service locations by persons not expressly approved by Cameron.

Product Brand

Barton® is a registered trademark of Cameron International Corporation ("Cameron").

MEASUREMENT SYSTEMS

Formerly: NuFlo Measurement Systems • Barton Instrument Systems • Caldon, Inc.

HOUSTON
HEAD OFFICE | **281.582.9500**

NORTH
AMERICA | **1.800.654.3760**
ms-us@c-a-m.com

ASIA
PACIFIC | **+603.2287.1039**
ms-asiapacific@c-a-m.com

EUROPE,
MIDDLE EAST
& AFRICA | **+44.1243.826741**
ms-uk@c-a-m.com

USA • CANADA • UK • SCOTLAND • CHINA • UAE
ALGERIA • MALAYSIA • SINGAPORE • www.c-a-m.com/flo

