

June 12, 2019

Instructions to alter the position of a Floco register

The Floco positive displacement flow meter may by itself be mounted in any orientation. The capability is valuable when considering that the Floco must be installed in certain locations within the piping such as upstream of the level control valve on a separator. When the optional proportional sampler is installed on the Floco some orientations limitations apply, examine the sampler literature for more details.

The optimal meter installation location may make the mechanical volume register difficult to view when it is in the factory standard position. Fortunately, the Floco is designed to enable the register position to be easily changed at any time. The flow does not need to be interrupted to change the register position and only a medium blade slotted screw driver is required. It is helpful if the screw driver has a shaft that is at least 6" (15 cm) long. The screws are filister head type which provides a deep slot to better engage the screw driver.

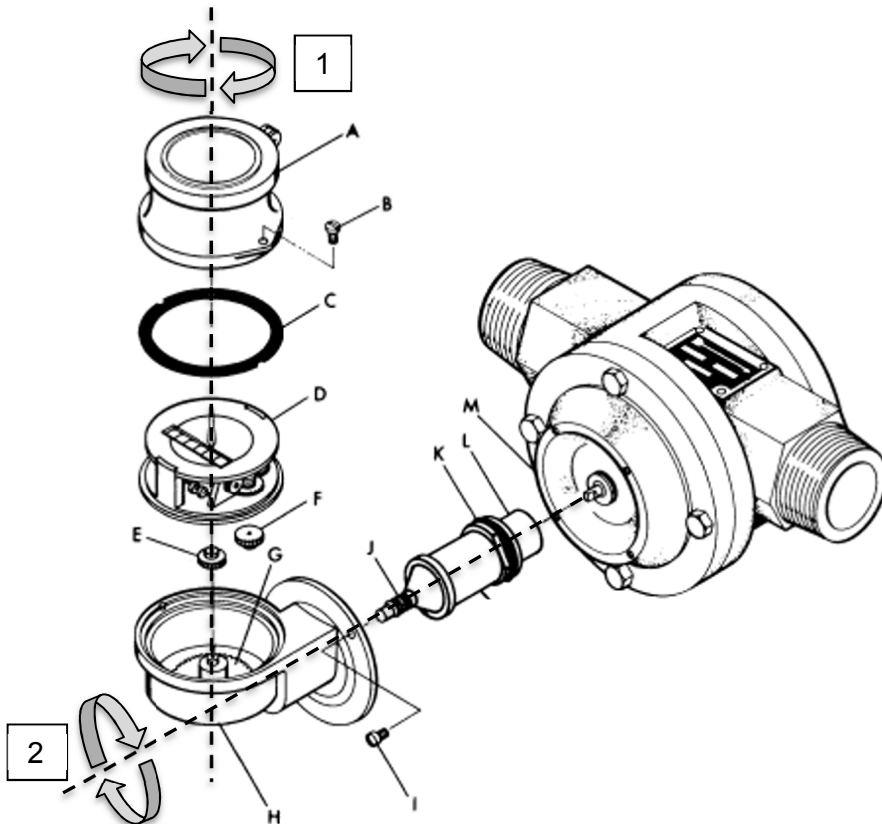

The register position of item (D) can be changed in any combination of two axis (1 or 2) in 90-degree increments.

To change the position on axis (2), remove the four screws (I) that engage the body (M). Access to the screw that is adjacent to screw (I) that is shown is obscured by the lobe shape to register housing (H). Access can be achieved either by using another screwdriver with a 90-degree shaft or by following the instructions for change of position for axis (1) as an intermediate step. With the screws removed rotate (H) to the desired position. It is not necessary to pull (H) way from the body (M) and expose parts (J,K,L). When rotating (H) it may be snug since O-ring (K) is creating a weatherproof seal to the interior of (H).

Replace the screws.

To change the position on axis (1), remove the two screws (B) that engage the register adapter (H). Remove items (A & C), item D can be rotated to the desired position without removing it. If this process is being followed as part of the axis (2) instructions, then lift (F) straight up. Parts (E & F) will remain in place as they are attached to companion parts. Complete axis 2 positioning as desired. Place (D) back into position desired. Place (C, A & D) into desired position and tighten screws.

Yours truly,
Cameron, A Schlumberger Company

Don Hammill
Product Manager
Tel 1 403 816 5717
dhammill@cameron.slb.com