

JISKOOT

JetLine Line Conditioning, Sampling and Analysis System

Installation and Operation Manual

Important Safety Information

Safety Guidelines

Observe all safety notices in this manual to ensure your personal safety and prevent damage to property. Notices referring to your personal safety are highlighted in red and marked with a safety alert symbol.

 **DANGER or CAUTION NOTICE.** Indicates that death or severe personal injury may result if proper precautions are not taken.

 **INFORMATION NOTICE.** Indicates that an unintended result or situation can occur if the corresponding notice is not taken into account.

*Mark of Schlumberger.

Other company, product, and service names are the properties of their respective owners.

Copyright © 2018 Schlumberger Limited. All rights reserved.

TABLE OF CONTENTS

Safety Guidelines	i
SECTION 1: INTRODUCTION	5
Introduction.....	5
The JetLine Difference	5
SECTION 2: SYSTEM OVERVIEW.....	7
Technical Specifications.....	7
Integrated System Engineering.....	7
<i>Inline Configuration</i>	7
<i>Fast Loop Configuration</i>	8
SECTION 3: INSTALLATION.....	9
Lifting and Handling	9
<i>Lifting Arrangement</i>	9
Mounting Orientation.....	10
Dimensions.....	10
Torque Procedure	11
SECTION 4: COMMISSIONING AND MAINTENANCE	13
Retrofit Installation Pre-Checks.....	13
System Pre-Checks	13
Operational Tests.....	13
Maintenance.....	14
APPENDIX A: OPTIONAL QUILL INSTALLATION	15
WARRANTY.....	17

Section 1: Introduction

Introduction

The JISKOOT JetLine* System is a compact dynamic line conditioning system that provides custody-transfer quality line conditioning for light-density, low-viscosity fluids in line sizes 8 inches and smaller. Its non-intrusive design minimizes fluid alteration caused by pressure drop, making it ideal for custody transfer, allocation, and production applications.

The design enables pigging operations, unlike static mixers, and it is easily retrofitted with existing inline and fast loop sampling systems.



Figure 1.1—JISKOOT JetLine line conditioning, sampling and analysis system

The JetLine Difference

Creating a homogeneous fluid with light-density, low-viscosity crude oils and condensates can be a challenge using static mixer and traditional jet-mix technologies that use quills and nozzles to extract and re-inject fluids into the pipeline. Because static mixers mix fluids by obstructing flow with plates or baffles, they often cannot create the turbulence necessary to mix ultra-light density/low-viscosity fluids.

Traditional jet-mix systems mix low-viscosity fluids using the fluid that has been taken from the line, re-injecting it through a jetted nozzle that protrudes into the pipeline. This technology works very well in larger pipeline sizes, but in line sizes 8 in. (200 mm) and smaller, the jetted nozzle can obstruct the flow of the fluid, which can create a pressure drop sufficient to turn liquid into a gas.

To avoid issues with pressure drop in the custody-transfer process, fluid must be pumped at an adequately high pressure. This requires an increase in energy at the pump, which increases operational costs for the life of the project. Additionally, a pressure drop immediately before the sample point can alter the physical properties of the fluid, bringing uncertainty to the fluid's appraisal.

The JetLine System creates a truly homogenous fluid without obstructing the line before the sample point, enabling improved sampling representativity, better-quality data, and pigging of the line without removing probes, quills, or nozzles. A fully homogeneous mix means that any water is fully dispersed across the full cross-section of pipe.

Section 2: System Overview

Technical Specifications

Pipeline diameter	3", 4", 6" and 8" (80 mm, 100 mm, 150 mm and 200 mm)
Process connections	Raised-face (RF) flanges
ANSI pressure rating range	Class 150, 300, 600
Temperature	-4°F to 212°F (-20°C to 100°C)
Density range	5.84-7.9 lbm/galUS (700-950 kg/m ³); consult factory for process conditions outside of this range
Viscosity, minimum	0.001 in ² /s (0.65 mm ² /s)
Viscosity, maximum	0.542 in ² /s (350 mm ² /s)
Water cut range	0-100 %
Materials	Low temperature LF2, 316 stainless steel, and duplex

Pressure containment certification is available. Contact Cameron for details.

Integrated System Engineering

The JISKOOT JetLine system can be configured in a standard inline or fast-loop configuration.

Inline Configuration

In an inline (or "JetMix*") configuration, the fluid is reinjected via jetted nozzles that are radially mounted within the pipe wall of the JetLine system spool. By jetting the fluid into the flow stream, the system adds energy into the pipeline near the location where the representative sample will be taken. This can be used in front of an existing inline sample probe or fast-loop sampling system.

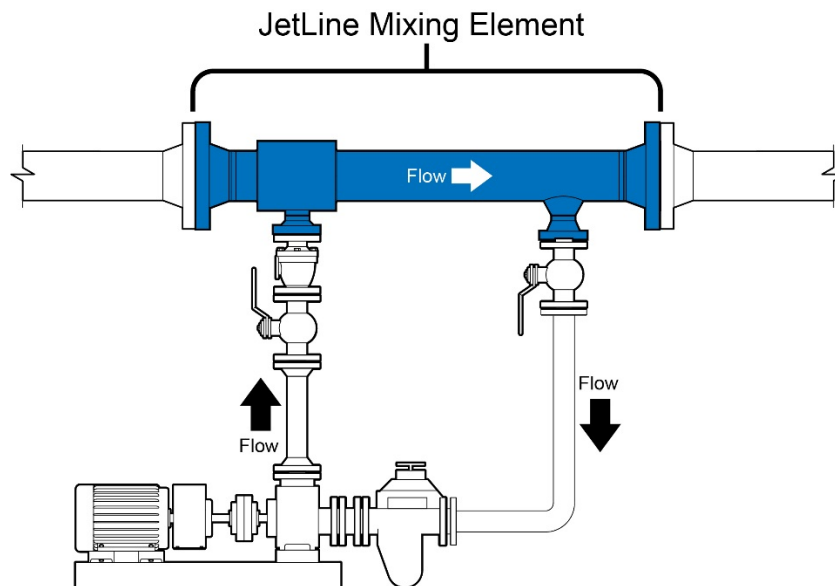

Figure 2.1—Inline configuration illustration

Fast Loop Configuration

A fast loop configuration is similar to the inline loop design with a pump-driven flow loop. Instead of installing the sampler after the conditioning loop, a cell sampler and other analytical device, such as a densitometer or water in oil meter (WIOM), is placed into the flow loop. This enables operators to receive a representative sample and real-time analytical data for fluid within the pipeline.

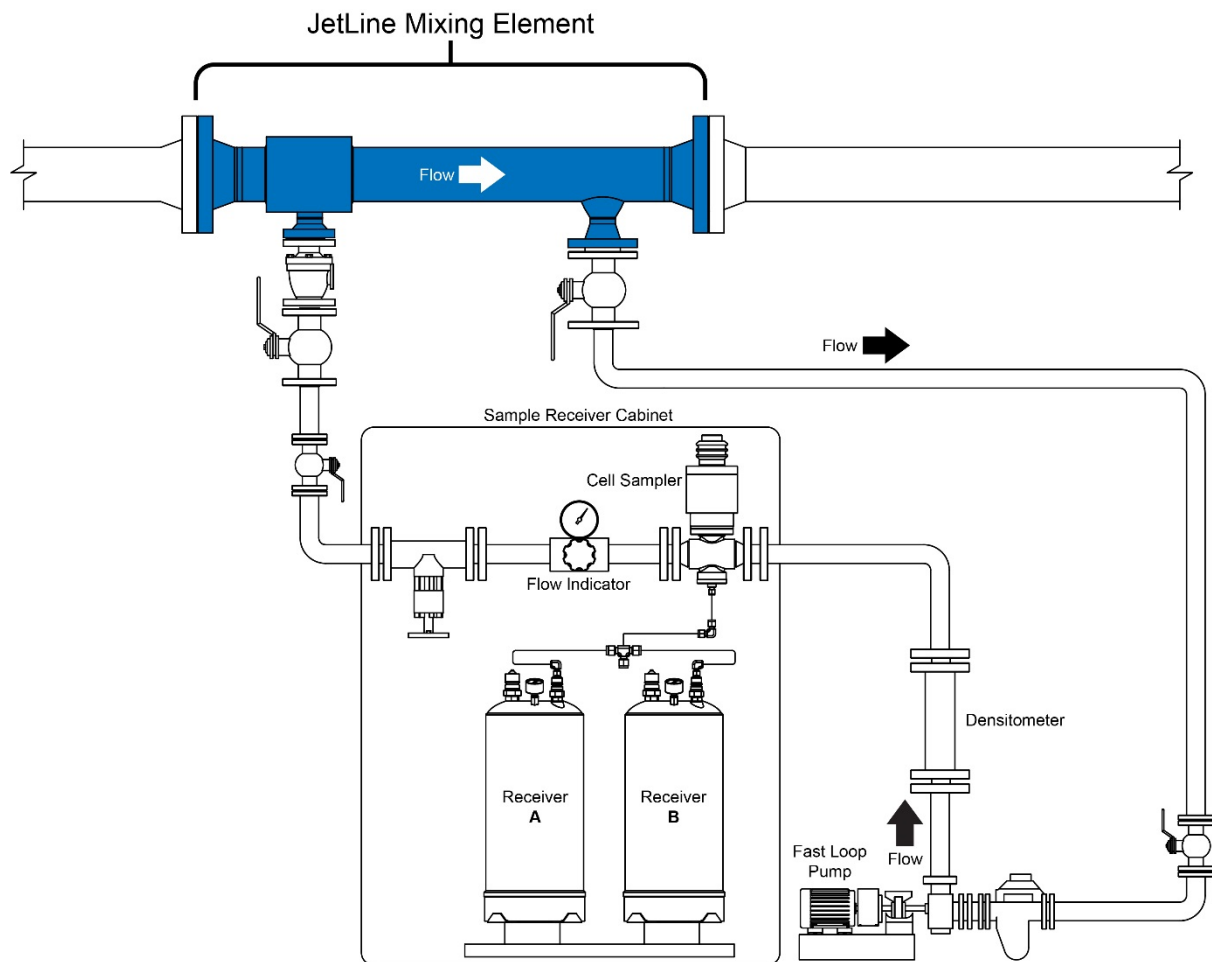

Figure 2.1—Fast loop configuration illustration

Section 3: Installation

- ⚠ The following instructions assume a degree of general knowledge regarding the components used in these systems. These instructions should be read in conjunction with the system piping and instrumentation diagram.
- ⚠ Be safe. Ensure that personal protection equipment is used at all times.
- ⚠ Ensure that all national and site safety procedures and safe working practices are followed at all times.
- ⚠ Obtain all necessary site permits before carrying out any work.

Lifting and Handling

Lifting Arrangement

Lift the JetLine mixing chamber spool into and out of place during installation or maintenance using slings at two (2) lifting points as illustrated in Figure 3.1.

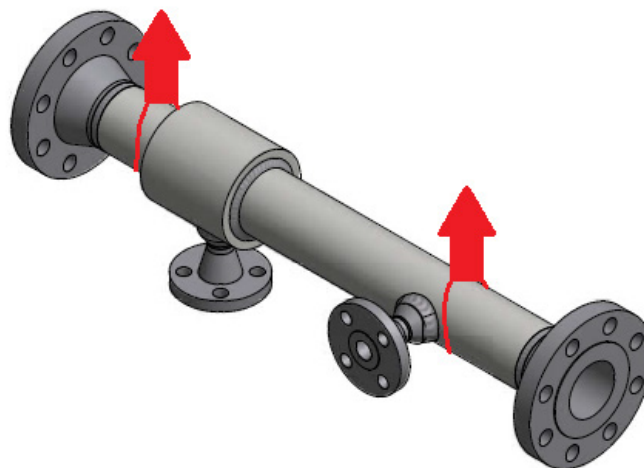

Figure 3.1—JetLine lifting diagram

When determining the appropriate lifting equipment, consider the approximate dry weight of the JetLine system shown in the table below.

Main Line Size in. [mm]	Dry Weight lb [kg]
3 [80]	86 [39]
4 [100]	156 [71]
6 [150]	349 [158]
8 [200]	661 [300]

Dry weights vary, depending on the configuration used. The weights shown above are based on a system designed for Class 300 pressure and Schedule 40 piping without a bolted quill. Always refer to flange tables to calculate the weight of a JetLine system for a given installation before determining proper lifting procedures.

Mounting Orientation

Install the JetLine system in a horizontal orientation with the mainline process flow in the direction of the arrow marked on the nameplate, as illustrated below.

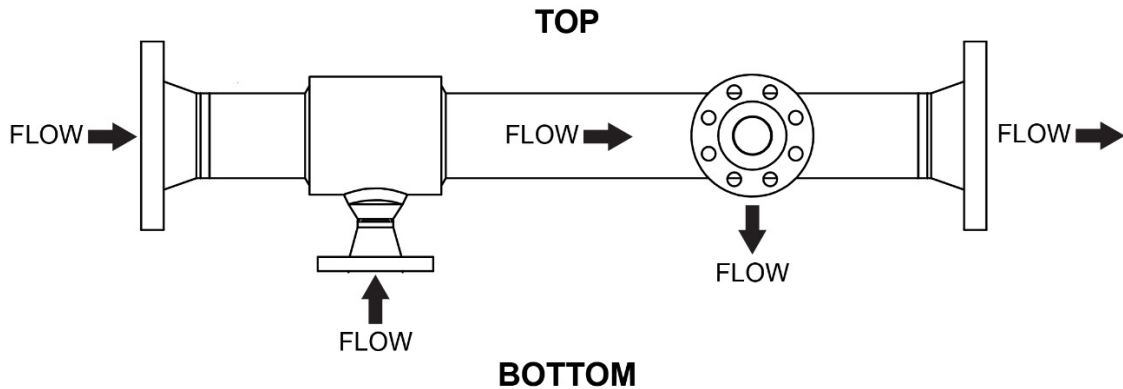

Figure 3.2—JetLine flow orientation

In tests at an internationally accredited laboratory, the JetLine system performed to specifications both with and without a quill. If a quill is desired in the installation, insert the quill so the aperture is facing the direction of flow and bolt it to the JetLine take-off flange. For more details, see Appendix A.

Dimensions

Face-to-face dimensions (X) and dimensions for the overall envelope of the JetLine (Y and Z) are provided in the tables below.

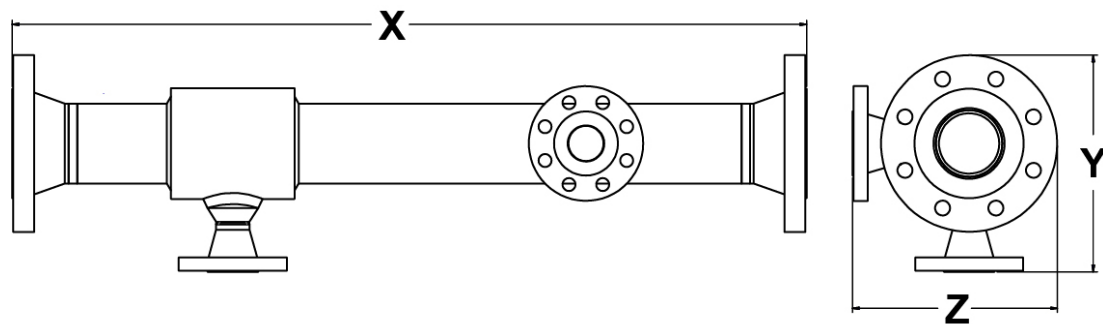

Figure 3.3—JetLine dimensional diagram

JetLine for 3" (80 mm) Pipeline				
Pressure Rating	X	Y	Z (no quill)	Z (with quill)
150 Class	889 mm	248 mm	226 mm	N/A
300 Class	889 mm	264 mm	242 mm	N/A
600 Class	889 mm	270 mm	248 mm	N/A

JetLine for 4" (100 mm) Pipeline				
Pressure Rating	X	Y	Z (no quill)	Z (with quill)
150 Class	1143 mm	292 mm	277 mm	289 mm
300 Class	1143 mm	312 mm	296 mm	311 mm
600 Class	1143 mm	323 mm	308 mm	324 mm

JetLine for 6" (150 mm) Pipeline				
Pressure Rating	X	Y	Z (no quill)	Z (with quill)
150 Class	1651 mm	354 mm	328 mm	341 mm
300 Class	1651 mm	379 mm	354 mm	369 mm
600 Class	1651 mm	408 mm	382 mm	398 mm

JetLine for 8" (200 mm) Pipeline				
Pressure Rating	X	Y	Z (no quill)	Z (with quill)
150 Class	2159 mm	412 mm	397 mm	410 mm
300 Class	2159 mm	437 mm	426 mm	439 mm
600 Class	2159 mm	466 mm	455 mm	480 mm

Torque Procedure

The JetLine system’s ANSI B16.5 flanged connections must be bolted to the flanges of an existing sampling system.

Cameron recommends the use of bolting material in accordance with ASTM A193 or ASTM A320 where appropriate.

These bolts must be torqued to the required bolt torque loads for the relevant flange size and pipe rating as outlined by the bolt manufacturer.

Caution Always apply torque to bolts in stages following a prescribed pattern to avoid point loading. This pattern is illustrated below for 4-bolt, 8-bolt, and 12-bolt flange configurations.





Figure 3.4—Torque patterns for 4-bolt, 8-bolt, and 12-bolt flanges

Torque the bolts in three (3) stages to evenly distribute the torque load across the flange circumference.

1. Torque all bolts to one-third of the final required torque (stage one).
2. Torque all bolts to two-thirds of the final torque (stage two).
3. Torque all bolts to the final torque (stage three).
4. Apply full torque to all bolts in a final pass, working in a clockwise direction from bolt 1.

Section 4: Commissioning and Maintenance

-  **Be safe. Ensure that personnel protection equipment is used at all times.**
-  **Ensure that all national and site safety procedures and safe working practices are followed at all times.**
-  **Obtain all necessary site permits before carrying out any work.**

Retrofit Installation Pre-Checks

The following checks should be performed before attempting to operate a sampling system containing a retrofit JetLine mixing element.

System Pre-Checks

The following checks should be performed before attempting to operate a JetLine sampling system.

- Mechanically inspect all line components and confirm that they are installed in accordance with the project drawings and installation guidelines.
- Check all stud-sets are of the correct size / length and that they are fully tightened.
- Confirm that the JetLine and site piping has been successfully pressure tested.
- Check all accessible double ferrule compression fittings with an appropriate NoGo Gauge and ensure tightness.
- Ensure the provision of a suitable safety earth connection to the skid base, ensuring that the wire does not present any trip hazard.
- Check the support of all system and power cables and that suitable, certified cable glands have been used.
- Confirm that the site cables have been continuity tested and that all cable cores are securely terminated.
- Check that certified blanking plugs are fitted to any unused cable entries.
- Ensure the fitting and effectiveness of all safety covers.
- The alignment of any pumps should also be checked prior to starting up system.

Operational Tests

The following checks are the minimum required for a JISKOOT sampling system. If applicable, a supplementary commissioning procedure will be provided.

Make sure the pipeline is full of oil before attempting to operate the system.

- Introduce flow to the system (start pumps, etc.)
- Ensure that copies of all operating procedures are available on site for the Operators and Maintenance personnel.
- Ensure the site operators are familiar with the operating procedures, aware of system specifications, and confident in their ability to execute operations for which the system is designed.
- Ensure that all relevant safety locks, emergency stops are operational.

Maintenance

The JetLine system requires no routine maintenance since there are no moving parts to repair or replace.

Appendix A: Optional Quill Installation

Where required by the process conditions, a quill may be included in a JetLine system. This optional quill is bolted as a fixed part to the horizontal take-off flange and installed with the opening facing into the direction of flow.

Before installing a quill, make sure the JetLine system is depressurized and drained.

To install the quill

- Bolt the JetLine quill to the downstream horizontal take-off flange (Fig. A.1), ensuring that the opening of the quill faces the direction of flow. A flow direction arrow is located on the external flange to aid installation.
- Fit all interconnecting pipework and instrumentation, as applicable, to the JetLine assembly and process control loop.

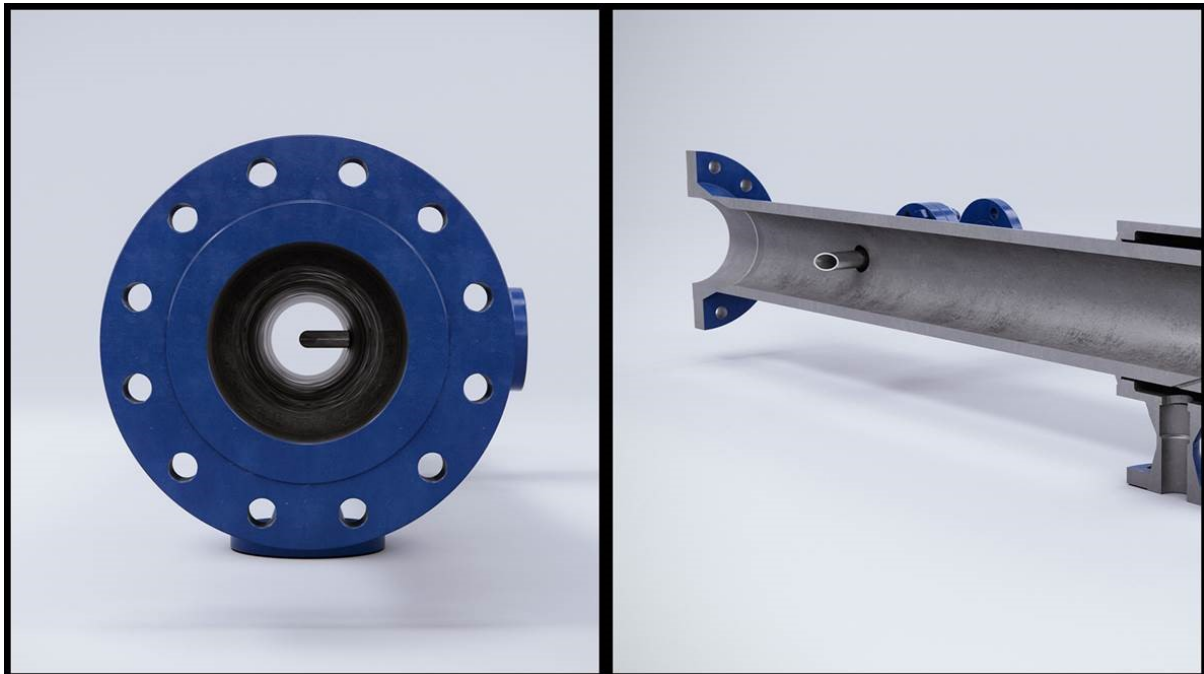

Figure A.1—Proper quill installation

WARRANTY

WARRANTY - LIMITATION OF LIABILITY: Seller warrants only title to the products, software, supplies and materials and that, except as to software, the same are free from defects in workmanship and materials for a period of one (1) year from the date of delivery. Seller does not warrant that software is free from error or that software will run in an uninterrupted fashion. Seller provides all software 'as is'. THERE ARE NO WARRANTIES, EXPRESS OR IMPLIED, OF MERCHANTABILITY, FITNESS OR OTHERWISE WHICH EXTEND BEYOND THOSE STATED IN THE IMMEDIATELY PRECEDING SENTENCE. Seller's liability and Buyer's exclusive remedy in any case of action (whether in contract, tort, breach of warranty or otherwise) arising out of the sale or use of any products, software, supplies, or materials is expressly limited to the replacement of such products, software, supplies, or materials on their return to Seller or, at Seller's option, to the allowance to the customer of credit for the cost of such items. In no event shall Seller be liable for special, incidental, indirect, punitive or consequential damages. Seller does not warrant in any way products, software, supplies and materials not manufactured by Seller, and such will be sold only with the warranties that are given by the manufacturer thereof. Seller will pass only through to its purchaser of such items the warranty granted to it by the manufacturer.

